



---

A Sierra Monitor Company

**Driver Manual**  
**(Supplement to the FieldServer Instruction Manual)**

**FS-8700-73 BACnet MSTP - Serial**

**APPLICABILITY & EFFECTIVITY**

**Effective for all systems manufactured after August 2008**

<b>Driver Version:</b>	<b>1.00</b>
<b>Document Revision:</b>	<b>25</b>

## TABLE OF CONTENTS

<b>1.</b>	<b>BACNET MSTP DESCRIPTION .....</b>	<b>3</b>
<b>2.</b>	<b>DRIVER SCOPE OF SUPPLY .....</b>	<b>4</b>
2.1.	Supplied by FieldServer Technologies for this driver.....	4
2.2.	Provided by the Supplier of 3 <sup>rd</sup> Party Equipment .....	4
2.2.1.	<i>Required 3<sup>rd</sup> Party Hardware .....</i>	4
2.2.2.	<i>Optional Items .....</i>	4
<b>3.</b>	<b>HARDWARE CONNECTIONS.....</b>	<b>5</b>
3.1.	Hardware connection Tips/Hints .....	6
<b>4.</b>	<b>CONFIGURING THE FIELDSEVER AS A BACNET MSTP CLIENT.....</b>	<b>7</b>
4.1.	Data Arrays/Descriptors.....	7
4.2.	Setting the FieldServer Node_ID.....	7
4.3.	Client Side Connection Descriptions .....	8
4.4.	Client Side Node Descriptors .....	9
4.5.	Client Side Map Descriptors.....	10
4.5.1.	<i>FieldServer Related Map Descriptor Parameters .....</i>	10
4.5.2.	<i>Driver Related Map Descriptor Parameters.....</i>	10
4.5.3.	<i>Timing Parameters .....</i>	10
4.5.4.	<i>Map Descriptor Example.....</i>	11
<b>5.</b>	<b>CONFIGURING THE FIELDSEVER AS A BACNET MSTP SERVER.....</b>	<b>12</b>
5.1.	Driver Specific FieldServer Parameters .....	12
5.2.	Server Side Connection Descriptors .....	13
5.3.	Server Side Node Descriptors.....	13
5.4.	Server Side Map Descriptors .....	15
5.4.1.	<i>FieldServer Specific Map Descriptor Parameters.....</i>	15
5.4.2.	<i>Driver Specific Map Descriptor Parameters .....</i>	15
5.4.3.	<i>Map Descriptor Example.....</i>	16
<b>APPENDIX A.</b>	<b>DRIVER NOTES.....</b>	<b>17</b>
Appendix A.1.	Data_Type Legal Values – Abbreviation Descriptions.....	17
<b>APPENDIX B.</b>	<b>ADVANCED TOPICS .....</b>	<b>18</b>
Appendix B.1.	BACnet Object Names .....	18
Appendix B.2.	BACnet Priority Arrays .....	18
Appendix B.3.	Limitations of the BACnet Read_Property_Multiple service.....	18
Appendix B.4.	BACnet State Text Preload .....	19
<b>APPENDIX C.</b>	<b>TROUBLESHOOTING TIPS .....</b>	<b>20</b>
Appendix C.1.	Debugging a BACnet connection: Hints and tips.....	20
Appendix C.2.	BACnet Specific Statistics.....	21
Appendix A.1.	Network number.....	21
Appendix C.3.	Known problems with third party devices - Automated Logic Corporation. ...	21
<b>APPENDIX D.</b>	<b>UNITS .....</b>	<b>22</b>

## 1. BACnet MSTP Description

The BACnet Master-Slave/Token-Passing (MSTP) driver implements a data link protocol that uses the services of the RS-485 physical layer. See the FieldServer BACnet PIC statement for the level of conformance that this driver implements.

### **Max Nodes Supported**

<b>FieldServer Mode</b>	<b>Nodes</b>	<b>Comments</b>
Client	1	
Server	32	

**2. Driver Scope of Supply**

**2.1. Supplied by FieldServer Technologies for this driver**

FieldServer Technologies PART #	Description
FS-8917-16	RJ45 to terminal connector cable.

**2.2. Provided by the Supplier of 3<sup>rd</sup> Party Equipment**

**2.2.1. Required 3<sup>rd</sup> Party Hardware**

Part #	Description
	Building control unit (BCU) <sup>1</sup>
	BACnet client such as a Trane Tracer Summit workstation <sup>2</sup>

**2.2.2. Optional Items**

PART #	Vendor/Manufacturer	Description
FS-4301-00	FieldServer	RS-232 to RS-485 converter

<sup>1</sup> If FieldServer used as BACnet Client.

<sup>2</sup> If FieldServer used as BACnet Server

### 3. Hardware Connections

The FieldServer is connected to the BACnet MSTP as shown in connection drawing.  
 Configure the BACnet MSTP according to manufacturer's instructions

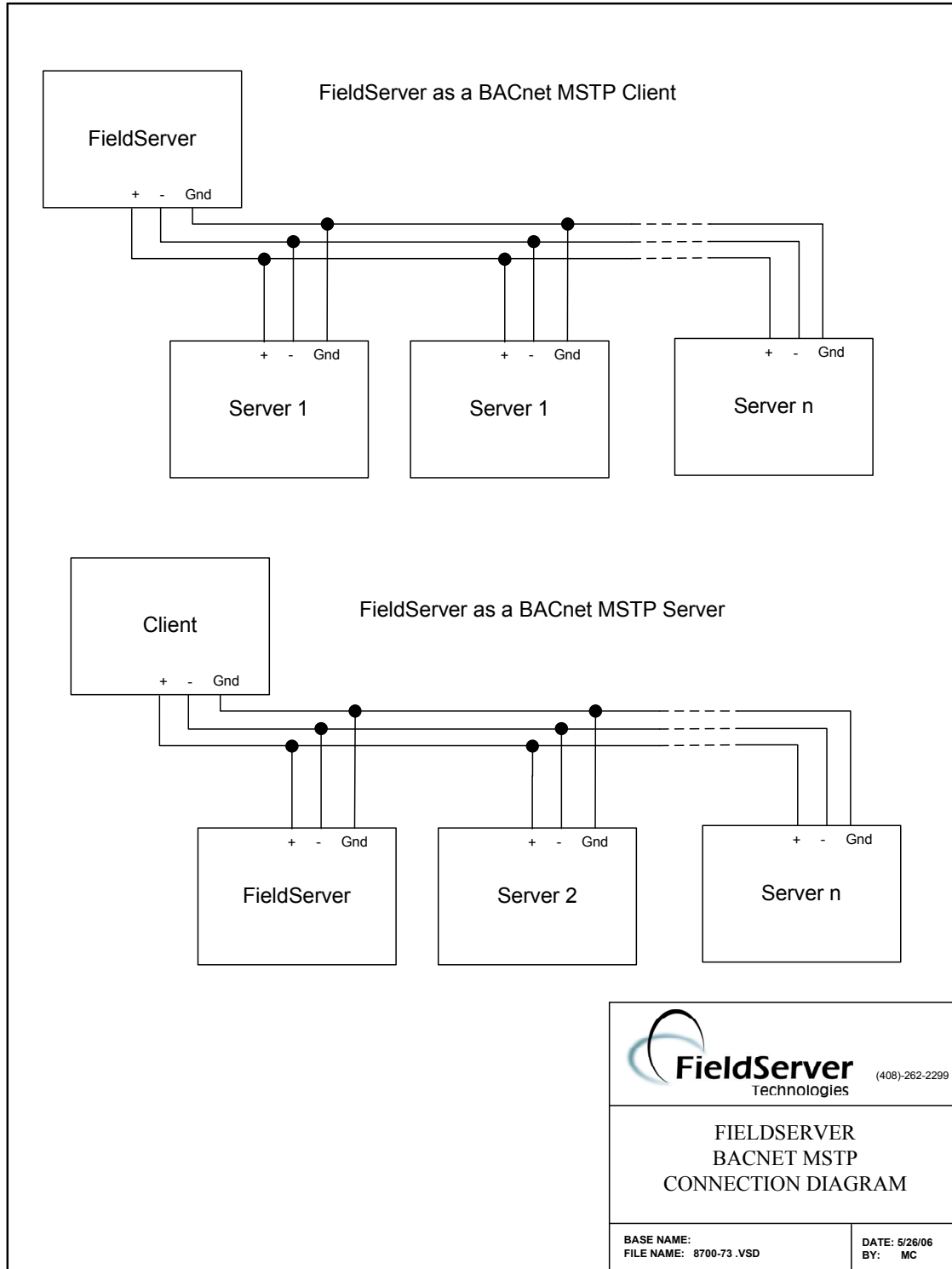

**3.1. Hardware connection Tips/Hints**

Follow standard RS-485 2-wire guidelines for installation. See connection diagram below.

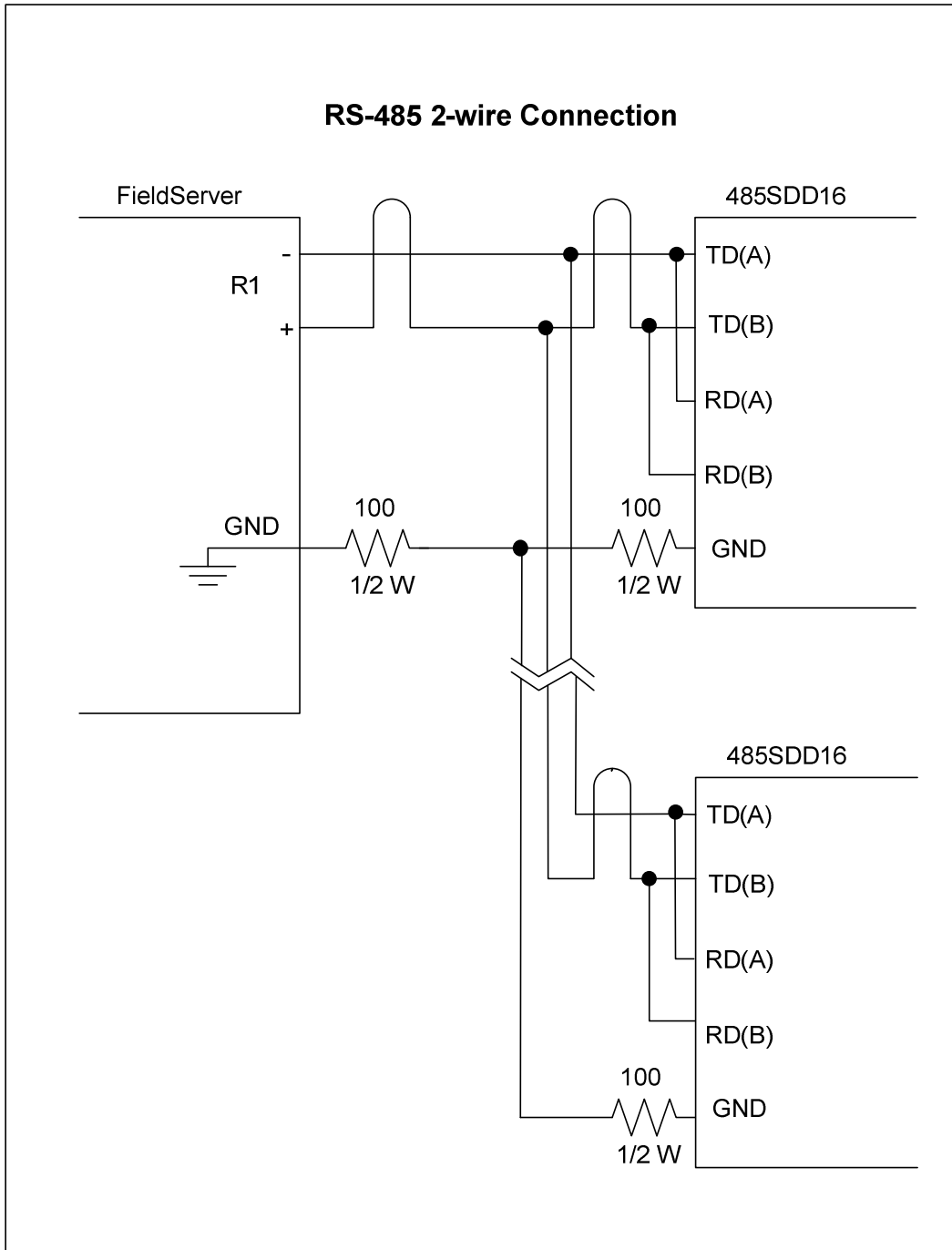

#### 4. Configuring the FieldServer as a BACnet MSTP Client

For a detailed discussion on FieldServer configuration, please refer to the FieldServer Configuration Manual. The information that follows describes how to expand upon the factory defaults provided in the configuration files included with the FieldServer (See “.csv” sample files provided with the FieldServer).

This section documents and describes the parameters necessary for configuring the FieldServer to communicate with a BACnet MSTP Server.

##### 4.1. Data Arrays/Descriptors

The configuration file tells the FieldServer about its interfaces, and the routing of data required. In order to enable the FieldServer for BACnet MSTP communications, the driver independent FieldServer buffers need to be declared in the “Data Arrays” section, the destination device addresses need to be declared in the “Client Side Nodes” section, and the data required from the servers needs to be mapped in the “Client Side Map Descriptors” section. Details on how to do this can be found below.

Note that in the tables, \* indicates an optional parameter, with the bold legal value being the default.

Section Title		
Data_Arrays		
Column Title	Function	Legal Values
Data_Array_Name	Provide name for Data Array	Up to 15 alphanumeric characters
Data_Format	Provides data format	Float, Bit, Uint16, Uint32, Sint16, Sint32, Packed_Bit, Byte, Packed_Byte, Swapped_Byte
Data_Array_Length	Number of Data Objects	1-10,000

##### Example

```
// Data Arrays
Data_Arrays
Data_Array_Name,      Data_Array_Format,      Data_Array_Length
DA_AI_01,             Float,                  200
DA_AO_01,             Float,                  200
DA_DI_01,             Bit,                    200
DA_DO_01,             Bit,                    200
```

##### 4.2. Setting the FieldServer Node\_ID

Section Title		
FieldServer		
Column Title	Function	Legal Values
System_Node_ID	Specify the MAC_Address of the FieldServer. (See Appendix C.1)	1-254

##### Example

```
// FieldServer
FieldServer
Title,                System_Node_ID
BACnet_MSTP,         11
```

**4.3. Client Side Connection Descriptions**

Section Title		
Connections		
Column Title	Function	Legal Values
Port	Specify which port the device is connected to the FieldServer	P1-P8 <sup>3</sup> , R1-R2 <sup>4</sup>
Baud	Specify baud rate	<b>9600</b> , 38400, 76800 <sup>5</sup>
Parity*	Specify parity	Odd, Even, <b>None</b>
Data_Bits*	Specify data bits	<b>7, 8</b>
Stop_Bits*	Specify stop bits	<b>1, 2</b>
Protocol	Specify protocol used	BACnet_MSTP
Poll Delay*	Time between internal polls	0-32000s, <b>1s</b>
Timeout	Application logger timeout	30s
Max_Master**	Specify the highest possible MAC_Address that exists on the MSTP network. (See Appendix C.1)	<b>1-127</b>
Max_Info_Frames	Specify the maximum number of information frames the connection may send before it must pass the token.	<b>1-65535</b>

**Example**

```
// Client Side Connections

Connections
Port, Baud, Parity, Data_Bits, Stop_Bits, Protocol, Poll_Delay, Timeout
R1, 38400, None, 8, 1, BACnet_MSTP, 0.100s, 30s
```

<sup>3</sup> P<sub>1</sub> to P<sub>8</sub> will require the optional RS-485 converter (Part # 4301-00)

<sup>4</sup> Not all ports shown are necessarily supported by the hardware. Consult the appropriate Instruction manual for details of the ports available on specific hardware.

<sup>5</sup> 76800 baud is supported on the X30, X25 and ProtoCessor



**4.4. Client Side Node Descriptors**

Section Title		
Nodes		
Column Title	Function	Legal Values
Node_Name	Provide name for node	Up to 32 alphanumeric characters
Node_ID	Specify the BACnet Device object instance. <sup>6</sup>	1 - 4194303
Protocol	Specify protocol used	BACnet_MSTP
Port	Specify port	P1-P8 <sup>7</sup> , R1-R2 <sup>8</sup>
MAC_Address	MAC_Address of the physical server node. <sup>6</sup>	1-127 (for Master Nodes) 1-254 (for Slave Nodes)
Network_Number*	Use this parameter if the remote MSTP server device is on another BACnet network connected via a router.	1,2,3.... 16 bit positive numbers. <b>5</b>

**Example**

```
// Client Side Nodes
Nodes
Node_Name,          Node_ID,          Protocol,          Port
BCU_1,              1,              BACnet_MSTP,     R1
```

<sup>6</sup> Either Node\_ID OR MAC\_Address must be specified. If the Server Node supports Who-Is and I-Am then it is better to use the Node\_ID parameter.

<sup>7</sup> P<sub>1</sub> to P<sub>8</sub> will require the optional RS-485 converter (Part # 4301-00)

<sup>8</sup> Not all ports shown are necessarily supported by the hardware. Consult the appropriate Instruction manual for details of the ports available on specific hardware.

**4.5. Client Side Map Descriptors**

**4.5.1. FieldServer Related Map Descriptor Parameters**

Column Title	Function	Legal Values
Map_Descriptor_Name	Name of this Map Descriptor	Up to 32 alphanumeric characters
Data_Array_Name	Name of Data Array where data is to be stored in the FieldServer	One of the Data Array names from "Data_Array" section
Data_Array_Offset	Starting location in Data Array	0 to Data_Array_Length-1 as specified in "Data_Array" section
Function	Function of Client Map Descriptor	Rdbc, Wrbc, Wrbx

**4.5.2. Driver Related Map Descriptor Parameters**

Column Title	Function	Legal Values
Node_Name	Name of Node to fetch data from	One of the node names specified in "Client Node Descriptor" above
Data_Type	Data type in FieldServer	AI, AO, AV, BI, BV, MI, MO, MV <sup>9</sup>
Object_Instance	Address of object	0, 1, 2, 3, ...
Property*	The BACnet property to be read	<b>Present_Value</b>
Data_Array_Low_Scale*	Scaling zero in Data Array	-32767 to 32767, <b>0</b>
Data_Array_High_Scale*	Scaling max in Data Array	-32767 to 32767, <b>100</b>
Node_Low_Scale*	Scaling zero in Connected Node	-32767 to 32767, <b>0</b>
Node_High_Scale*	Scaling max in Connected Node	-32767 to 32767, <b>100</b>
Write_Priority	Allows the driver to specify the write priority used to write an output. See also Appendix B.2	1..16, <b>16</b>
Custom_Type	This over-writes the Data_Type with a numerical value for the Data_Type. e.g. Analog Value = 2	1..1023
Custom_Prop	This over-writes the Property with a numerical value for the property. e.g. Present Value = 85	1..4194303

**4.5.3. Timing Parameters**

Column Title	Function	Legal Values
Scan_Interval*	Rate at which data is polled	0-32000, <b>2s</b>

<sup>9</sup> Refer to Appendix A.1 for further information.

**4.5.4. Map Descriptor Example.**

```
// Client Side Map Descriptors
```

Map_Descriptor_Name,	Data_Array_Name,	Data_Array_Offset,	Function,	Node_Name,	Data_Type,	Object_Instance	Property,	Scan_Interval
Map_Descriptors CMD_AI_01,	DA_AI_01,	0,	RDBC,	BCU_1,	AI,	1,	Present_Value,	20.000s
CMD_AI_02,	DA_AI_01,	1,	RDBC,	BCU_1,	AI,	2,	Present_Value,	20.000s
CMD_AI_03,	DA_AI_01,	2,	RDBC,	BCU_1,	AI,	3,	Present_Value,	20.000s
CMD_AO_01,	DA_AO_01,	0,	RDBC,	BCU_1,	AO,	1,	Present_Value,	30.000s
CMD_AO_02,	DA_AO_01,	1,	RDBC,	BCU_1,	AO,	2,	Present_Value,	30.000s
CMD_AO_03,	DA_AO_01,	2,	RDBC,	BCU_1,	AO,	3,	Present_Value,	30.000s
Map_Descriptors CMD_DI_01,	DA_DI_01,	0,	RDBC,	BCU_1,	DI,	1,	Present_Value,	15.000s
CMD_DI_02,	DA_DI_01,	1,	RDBC,	BCU_1,	DI,	2,	Present_Value,	15.000s
CMD_DI_03,	DA_DI_01,	2,	RDBC,	BCU_1,	DI,	3,	Present_Value,	15.000s
CMD_DO_01,	DA_DO_01,	0,	RDBC,	BCU_1,	DO,	1,	Present_Value,	30.000s
CMD_DO_02,	DA_DO_01,	1,	RDBC,	BCU_1,	DO,	2,	Present_Value,	30.000s
CMD_DO_03,	DA_DO_01,	2,	RDBC,	BCU_1,	DO,	3,	Present_Value,	30.000s

## 5. Configuring the FieldServer as a BACnet MSTP Server

For a detailed discussion on FieldServer configuration, please refer to the FieldServer Configuration Manual. The information that follows describes how to expand upon the factory defaults provided in the configuration files included with the FieldServer (See “.csv” sample files provided with the FieldServer).

This section documents and describes the parameters necessary for configuring the FieldServer to communicate with a BACnet MSTP Client.

The configuration file tells the FieldServer about its interfaces, and the routing of data required. In order to enable the FieldServer for BACnet MSTP communications, the driver independent FieldServer buffers need to be declared in the “Data Arrays” section, the FieldServer virtual node(s) needs to be declared in the “Server Side Nodes” section, and the data to be provided to the clients needs to be mapped in the “Server Side Map Descriptors” section. Details on how to do this can be found below.

Note that in the tables, \* indicates an optional parameter, with the bold legal value being the default.

### 5.1. Driver Specific FieldServer Parameters

Section Title		
Bridge		
Column Title	Function	Legal Values
Title	FieldServer name	Text
Network_Number*	Specify a unique network number if there are multiple virtual Server nodes.	1-255 <b>5</b>

#### Example

// FieldServer Driver specific parameters		
Bridge		
Title,	Network_Number	
Bacnet Server,	6	

**5.2. Server Side Connection Descriptors**

Section Title		
Connections		
Column Title	Function	Legal Values
Port	Specify which port the device is connected to the FieldServer	P1-P8 <sup>10</sup> , R1-R2 <sup>11</sup>
Baud	Specify baud rate	9600, 38400, 76800 <sup>12</sup>
Parity*	Specify parity	None, Odd, Even
Data_Bits*	Specify data bits	7, 8
Stop_Bits*	Specify stop bits	1, 2
Protocol	Specify protocol used	BACnet_MSTP
Connection_Type	Specify if the connection must be in Master_Mode or in Slave_Mode	MSTP_Master_Mode MSTP_Slave_Mode
Max_Master*	Specify the highest possible MAC_Address that exists on the MSTP network. Only applicable for MSTP_Master Mode connections. (See also section 4.7) <sup>13</sup>	1-127
Max_Info_Frames*	Specify the maximum number of information frames the connection may send before it must pass the token. Only applicable for MSTP_Master Mode connections. <sup>13</sup>	1-65535

**Example**

// Server Side Connections					
Connections					
Port,	Baud,	Parity,	Data_Bits,	Stop_Bits,	Protocol,
R1,	38400,	None,	8,	1,	BACnet_MSTP,

**5.3. Server Side Node Descriptors<sup>14</sup>**

Section Title		
Nodes		
Column Title	Function	Legal Values
Node_Name	Provide name for node	Up to 32 alphanumeric characters <sup>15</sup>
Node_ID	Node ID	1 - 4194303
Protocol	Specify protocol used	BACnet_MSTP

<sup>10</sup> P<sub>1</sub> to P<sub>8</sub> will require the optional RS-485 converter (Part # 4301-00)

<sup>11</sup> Not all ports shown are necessarily supported by the hardware. Consult the appropriate Instruction manual for details of the ports available on specific hardware.

<sup>12</sup> 76800 baud is supported on the X30, X25 and ProtoCessor

<sup>13</sup> For server configurations the Max\_Master and Max\_Info\_Frames parameters (or properties) can be overridden from a BACnet Client by using the "Write Property" command. Note that when the FieldServer is restarted, the default values as specified in the configuration file will be applied

<sup>14</sup> Only one Server Nodes may be defined for each connection. For information on support for multiple virtual server nodes on a single connection please contact the Sales Department."

<sup>15</sup> For HMI systems, this name will appear as the object name

**Example**

```
// Server Side Nodes
```

Nodes			
Node_Name,	Node_ID,	Protocol	<sup>16</sup>
Virtual_BCU_11,	11,	BACnet_MSTP	

---

<sup>16</sup> Note that adapter is not declared in the Server Side Nodes

**5.4. Server Side Map Descriptors**

**5.4.1. FieldServer Specific Map Descriptor Parameters**

Column Title	Function	Legal Values
Map_Descriptor_Name	Name of this Map Descriptor	Up to 32 alphanumeric characters.
Data_Array_Name	Name of Data Array where data is to be stored in the FieldServer	One of the Data Array names from "Data Array" section
Data_Array_Offset	Starting location in Data Array	0 to Data_Array_Length-1 as specified in "Data Array" section
Function	Function of Server Map Descriptor	Server

**5.4.2. Driver Specific Map Descriptor Parameters**

Column Title	Function	Legal Values
Node_Name	Name of FieldServer Node	One of the node names specified in "Server Node Descriptor" above
Data_Type	Data type in BCU	AI, AO, AV, BI, BV, MI, MO, MV <sup>17</sup>
Object_Instance	Address of the object	0, 1, 2, 3, ...
Units	The object units	Appendix 1
Data_Array_Low_Scale*	Scaling zero in Data Array	-32767 to 32767, <b>0</b>
Data_Array_High_Scale*	Scaling max in Data Array	-32767 to 32767, <b>100</b>
Node_Low_Scale*	Scaling zero in Connected Node	-32767 to 32767, <b>0</b>
Node_High_Scale*	Scaling max in Connected Node	-32767 to 32767, <b>100</b>
Active_Text	Specify the Active Text property of the Object <sup>18</sup>	Any legal BACnet ASCII string
Inactive_Text	Specify the Inactive Text property of the Object (See note <sup>12</sup> )	Any legal BACnet ASCII string
Relinquish_Default	Specify the startup Relinquish_Default Property value for this Object (See note <sup>12</sup> )	Any legal BACnet ASCII string
Custom_Type	This over-writes the Data_Type with a numerical value for the Data_Type. e.g. Analog Value = 2	1..1023
Custom_Prop	This over-writes the Property with a numerical value for the property. e.g. Present Value = 85	1..4194303

<sup>17</sup> Refer to Appendix A.1 for further information.

<sup>18</sup> See the BACnet DFS to determine if a particular object supports this property

**5.4.3. Map Descriptor Example.**

```
// Client Side Map Descriptors
Map_Descriptors
Map_Descriptor_Name, Data_Array_Name, Data_Array_Offset, Function, Node_Name, Data_Type, Object_Instance, Property, Units, Data_Array_Low_Scale, Data_Array_High_Scale, Node_Low_Scale, Node_High_Scale
SMD_AI_01, DA_AI_01, 0, Server, Virtual_BCU_11, AI, 1, Present_Value, Deg_F, 0, 10000, 10000, 0, 100
SMD_AI_02, DA_AI_01, 1, Server, Virtual_BCU_11, AI, 2, Present_Value, Deg_F, 0, 10000, 10000, 0, 100
SMD_AI_03, DA_AI_01, 2, Server, Virtual_BCU_11, AI, 3, Present_Value, Deg_F, 0, 10000, 10000, 0, 100
SMD_AO_01, DA_AO_01, 0, Server, Virtual_BCU_11, AO, 1, Present_Value, %RH, 0, 10000, 10000, 0, 100
SMD_AO_02, DA_AO_01, 1, Server, Virtual_BCU_11, AO, 2, Present_Value, %RH, 0, 10000, 10000, 0, 100
SMD_AO_03, DA_AO_01, 2, Server, Virtual_BCU_11, AO, 3, Present_Value, %RH, 0, 10000, 10000, 0, 100
```

```
Map_Descriptors
Map_Descriptor_Name, Data_Array_Name, Data_Array_Offset, Function, Node_Name, Data_Type, Object_Instance, Property
SMD_DI_01, DA_DI_01, 0, Server, Virtual_BCU_11, DI, 1, Present_Value
SMD_DI_02, DA_DI_01, 1, Server, Virtual_BCU_11, DI, 2, Present_Value
SMD_DI_03, DA_DI_01, 2, Server, Virtual_BCU_11, DI, 3, Present_Value
SMD_DO_01, DA_DO_01, 0, Server, Virtual_BCU_11, DO, 1, Present_Value
SMD_DO_02, DA_DO_01, 1, Server, Virtual_BCU_11, DO, 2, Present_Value
SMD_DO_03, DA_DO_01, 2, Server, Virtual_BCU_11, DO, 3, Present_Value
```



---

**Appendix A. Driver Notes**

---

**Appendix A.1. Data\_Type Legal Values – Abbreviation Descriptions**

**AI** Analog\_Input  
**AO** Analog\_Output  
**AV** Analog\_Value  
**BI** Binary\_Input  
**BV** Binary\_Value  
**MI** Multi\_State\_Input  
**MO** Multi\_State\_Output  
**MV** Multi\_State\_Value

**Appendix B. Advanced Topics**

**Appendix B.1. BACnet Object Names**

When an external BACnet Client builds a list of Object Names, the BACnet Server Map Descriptor name determines the BACnet Object Name. If the Map Descriptor length is greater than 1, then the Object Name will be suffixed with the index into the Map Descriptor. For example, if the Map Descriptor name is SMD\_AI\_01 and the length 3, then the Object Names will be SMD\_AI\_01[0], SMD\_AI\_01[1] and SMD\_AI\_01[2].

**Appendix B.2. BACnet Priority Arrays**

**FieldServer implementation of BACnet priority Arrays**

When BACnet Output objects are written to the Server side of the FieldServer, an associated write priority is given to each write value. When the FieldServer receives the write value, it stores it to the Map Descriptor Priority Array Table at the specified priority. The Priority Array Table is then scanned and the value with the highest priority is stored to the Data Array location specified by the Map Descriptor.

When a Write “Relinquished” command is received, the value is removed from the Priority Array Table and the next highest value from the Priority Array Table is stored to the Data Array.

If all values have been “Relinquished” from the Priority Array Table, then the Map Descriptors “Relinquish Default” value will be stored to the Data Array.

**Accessing Priority Array information**

The Priority Array table and its “In\_Use” (or Not Relinquished) state are stored internally to every Map Descriptor, and cannot be accessed directly. If the following data arrays are specified, however, they will maintain an exact copy of the Priority Array Table for the Map Descriptor. Thus the Priority Array Table can be accessed.

Section Title		
Map_Descriptors		
Column Title	Function	Legal Values
DA_Pri_Array	Name of Data Array where the Priority Array Table will be stored. Location 0 is the Relinquish Default value and locations 1 to 16 the different entries of the Priority Array Table.	Up to 16 alphanumeric characters
DA_Pri_Array_Offset	Starting location in Data Array.	1-65535 (17)
DA_Pri_In_Use	Name of Data Array that indicates if a particular Priority Values is in use. Location 0 indicate if the Relinquish Default has been set and locations 1 to 16 indicate if the index is in use (1), or if it has been Relinquished (0).	Up to 16 alphanumeric characters
DA_Pri_In_Use_Offset	Starting location in Data Array.	1-65535 (17)

**Appendix B.3. Limitations of the BACnet Read\_Property\_Multiple service.**

The BACnet PTP client driver can read multiple BACnet objects using the Read\_Property\_Multiple service under the following conditions:

- The number of objects to be read must not exceed 29.
- No gaps must exist in the range of object to be read.
- The Map Descriptor function must be of the Read type. (e.g. Rdbc)
- The Map Descriptor property must be Present Value.

**Appendix B.4. BACnet State Text Preload**

Method 1 – Using a Single Data Array:

Data_Arrays			
Data_Array_Name,	Data_Format,	Data_Array_Length	
DA_MI_01,	UINT16,	100	
DA_STATE_TXT,	BYTE,	200	

Preloads			
Data_Array_Name,	Preload_Data_Value,	Preload_Data_Format,	Preload_Data_Index
DA_STATE_TXT,	MyState1 MyState2 MyState3 MyState4 MyState5 MyState6,	String,	0

Map_Descriptors								
Map_Descriptor_Name,	Data_Type,	Object_ID,	Function,	Data_Array_Name,	Data_Array_Index,	Node_Name,	Length,	State_Text_Array
CMD_MI_01,	MI,	1	Server	DA_MI_01,	0,	N1 11,	1,	Da_State_Txt

Method 2 – Using an Offset/User Table:

//set up a look up table		
Offset_Table,	Table_String,	Table_Index_Value
FIRE_ALARM_TEXT,	SYSTEM READY,	0
FIRE_ALARM_TEXT,	ALARM,	1
FIRE_ALARM_TEXT,	MAINTENANCE,	2
FIRE_ALARM_TEXT,	OFF-LINE,	3
FIRE_ALARM_TEXT,	IN SERVICE,	4
FIRE_ALARM_TEXT,	OTHER,	5

Data_Arrays			
Data_Array_Name,	Data_Format,	Data_Array_Length	
DA_MI_01,	UINT16,	100	

Map_Descriptors								
Map_Descriptor_Name,	Data_Type,	Object_ID,	Function,	Data_Array_Name,	Data_Array_Index,	Node_Name,	Length,	State_Text_Array
CMD_MI_01,	MI,	1	Server	DA_MI_01,	1,	N1 11,	1,	Fire_Alrm_Text

---

**Appendix C. Troubleshooting Tips**

---

**Appendix C.1. Debugging a BACnet connection: Hints and tips**

- Disconnect the FieldServer from the BACnet network when transferring images to the BCU.
- If duplicate object instances are accidentally configured in the FieldServer, the second call of the instance will overwrite the first one. This may cause a BACnet Object to be “lost.”
- If “Virtual\_BCU\_...” is not being indicated as the device description for the FieldServer on the BACnet SCADA system, then the FieldServer is not communicating with the SCADA system. If the present value’s name is being indicated, but the present value shows question marks, then it is most likely that the Client side of the FieldServer is not communicating.
- When new points are added to the FieldServer it is important to restart the Summit Workstation or BCU, otherwise these new points may not be seen by the FieldServer.
- Polling BACnet addresses that are not configured for Lieberts systems may cause the connection to fail in older versions of Lieberts. Please contact your Lieberts supplier for more information.
- When a BACnet\_MSTP connection is configured as a server, it is better to use a connection\_type MSTP\_Slave\_Node. The only time when a server connection must be a Master\_Node is when alarming has been established on the FieldServer.
- Extra memory is required to store Map Descriptors that have the active/inactive text parameters specified. If the defaults are appropriate, do not specify these parameters. This will save memory and allow more Map Descriptors to be created.
- The FieldServer MAC\_Address is configured using the System\_Node\_ID field (See section 4.2) This MAC\_Address is used on the data\_link (or physical) layer as the source or destination addresses. See section 9.1.1.2 of the BACnet ANSI/ASHREA standard for more information. The MAC\_Address is not to be confused with the Node\_ID setting (Section 4.4) that specifies the BACnet device object instance.
- When designing the MSTP network with multiple Master\_Node devices, allocate the MAC\_Address settings on the different devices starting at 1. This will allow you to specify a small Max\_Master parameter and hence will improve overall network performance.
- When a FieldServer/ProtoCessor is configured to support MSTP virtual server nodes the firmware achieves this by implementing a virtual router and thus a network number is required so that it can expose its nodes to external devices as belonging to a specific network. (The default is network 5 if not specified). This network number is defined on the bridge descriptor as Network\_Number. It must be unique for a site. Refer also to Section 5.1, Section 4.4 and Appendix A.1.
- **McQuay Units** are shipped with a default Device instance of the last 6 digits of the McQuay Serial number.
- **Trane Specific Tips**
- When new points are added to the FieldServer it is important to restart Summit Workstation or BCU, otherwise these new points may not be seen by the FieldServer.
- Disconnect the FieldServer from the BACnet network when transferring images to the BCU

**Appendix C.2. BACnet Specific Statistics**

Stat	Description	Resolution
Link Control	A "who-is" link control message was sent or received.	It is normal to receive a few link control messages. If the number is higher than the transmit/receive messages, however, there may be a problem with lost communications..
Unsupported Properties	A request for an unsupported property was received.	This is not an error. BACnet clients often poll all properties of a particular object to determine which properties are supported.
Segmentation Not Supported	Data was requested but the response would have exceeded the maximum size of the APDU and could not be sent using an un-segmented message.	This is not an error - the BACnet client will use a different method to read data from the FieldServer.
Sequence Error	Invoke ID of a reply did not match the Invoke ID of the poll.	You should not see this message. It normally indicates a configuration error.
Write Access Denied	A write to an object was denied.	This typically happens when trying to write to an Input Object that is not Out-Of-Service. It is not possible to write to Input Objects.
Exception Errors	A BACnet Service was denied because it is not supported	This may be a problem on the Client system. Consult the PIC statement to determine what services are supported.

**Appendix A.1. Network Number**

If there are multiple FieldServers or third party devices on a BACnet Network each with multiple Server nodes a unique network number must be assigned to each device. This will ensure communication between the BACnet Client and all Servers.

For MSTP devices the network number is provided by the router.

A consequence of this is that when you configure a MSTP client you must know not only the Node\_ID of the server node but you need to know the network number. These are specified on the node descriptor for client applications as Node\_ID and Network\_Number. If the network number is not specified then the node is assumed to exist on the local segment.

Another consequence of this is that the network number is not relevant for server configurations.

The network number is a 16 bit positive number. To override the FieldServer's default network number 5, refer to Section 5.1

**Appendix C.3. Known problems with third party devices - Automated Logic Corporation.**

When an ALC module is powered up, and it does not detect valid BACnet/MSTP traffic on its MSTP port, then the module goes into a terminal mode and MSTP communications will never happen.

When connecting the FieldServer to an ALC BACnet/MSTP module, always start the FieldServer first. Wait until the RUN Led is flashing on the FieldServer before powering up the MSTP module.

**Appendix D. Units**

Unit	Variation 1	Variation 2	Variation 3
Amperes	Amps	A	
Bars			
BTUs			
BTUs-per-hour			
btus-per-pound			
btus-per-pound-dry-air			
centimeters			
centimeters-of-mercury			
centimeters-of-water			
cubic-feet			
cubic-feet-per-minute			
cubic-feet-per-seconds			
cubic-meters			
cubic-meters-per-hour			
cubic-meters-per-seconds			
Currency1			
Currency2			
Currency3			
Currency4			
Currency5			
Currency6			
Currency7			
Currency8			
Currency9			
Currency10			
cycles-per-hour			
cycles-per-minute			
days			
degrees-angular			
Degrees-Celsius	Deg-C	Deg_C	
degrees-celsius-per-hour			
degrees-celsius-per-minute			
Degrees-days-Celsius			
Degrees-days-Fahrenheit			
Degrees-Fahrenheit	Deg-F	Deg_F	
degrees-fahrenheit-per-hour			
degrees-fahrenheit-per-minute			
Degrees-Kelvin	Deg-K	Deg_K	
degrees-phase			
delta-degrees-fahrenheit			
delta-degrees-kelvin			
feet			
feet-per-minute			
feet-per-second			
foot-candles			
grams-water-per-kg-dry-air			
hectopascals			
Hertz	Hz		
Horsepower	HP		
hours			
imperial-gallons			
imperial-gallons-per-min			
inches			
inches-of-mercury			
inches-of-water			

Unit	Variation 1	Variation 2	Variation 3
Joules			
joules-per-degree-kelvin			
joules-per-kilogram-degree-kelvin			
joules-per-kilogram-dry-air			
Kilograms	Kg		
kilograms-per-hour			
kilograms-per-minute			
kilograms-per-second			
Kilohertz	KHz		
kilohms			
Kilojoules			
kilojoules-per-kilogram			
kilometers-per-hour			
Kilopascals			
kilovolt-amperes	kilovolt-amps	KVA	
kilovolt-amperes-reactive	KVAR		
kilovolts			
kilowatt-hour-per-square-foot			
kilowatt-hour-per-square-meter			
kilowatt-hours	KWh		
kilowatts	KWh		
liters			
liters-per-hour			
liters-per-minute			
liters-per-second			
lumens			
luxes			
Megahertz	MHz		
megajoules			
megajoules-per-square-foot			
megajoules-per-square-meter			
megavolt-amperes	megavolt-amps		
Megavolt-amperes-reactive	MVAR		
megavolts			
megawatts	MW		
megohms			
meters			
meters-per-second			
miles-per-hour			
milliamperes	milliamps		
millibars			
millimeters			
millimeters-of-mercury			
Millivolts			
Milliwatts			
minutes			
months			
No-Units	No Units	No_Units	None
ohms			
parts-per-billion			
parts-per-million			
Pascals			
Percent			
percent-obscuration-per-foot			
percent-obscuration-per-meter			
percent-per-second			
percent-relative-humidity	% RH	Percent RH	Percent RH
Per-hour			

Unit	Variation 1	Variation 2	Variation 3
per-minute			
per-second			
pounds-force-per-square-inch	PSI	pounds-force-per-sq-inch	
Pounds-mass			
pounds-mass-per-hour			
pounds-mass-per-minute			
pounds-mass-per-second			
Power-Factor	PF		
psi-per-degrees-fahrenheit			
radians			
revolutions-per-minute			
seconds	Secs	S	
square-centimeters			
square-feet			
square-inches			
square-meters			
Therms			
ton-hours			
Tons			
Tons-refrigeration			
US-gallons	Gallons		
us-gallons-per-minute	GPM		
Volt-Amperes	Volt-Amps	VA	
volt-amperes-reactive	VAR		
Volts	Voltage		
watt-hours	Wh		
Watts	W		
watts-per-square-foot			
watts-per-square-meter			
watts-per-square-meter-degrees-kelvin			
weeks			
years			